

LONG WALL STACKED ELEVATION

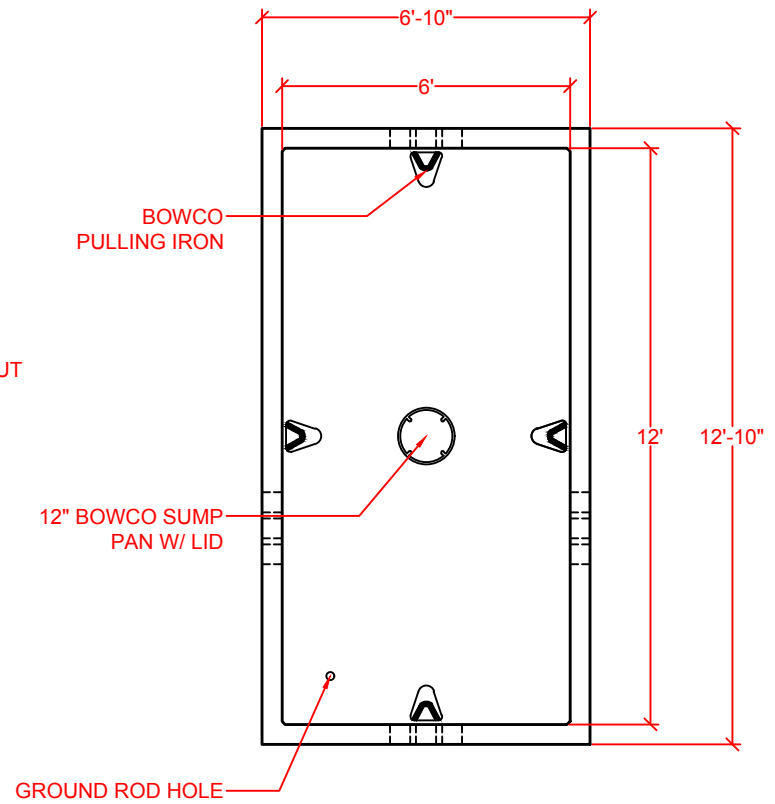

VAULT BASE: PLAN

TYPICAL STOCK COVER LETTERING:

- ELECTRIC
- COMMUNICATION

APPROXIMATE TOTAL WEIGHT: 30,850 LBS
 HEAVIEST PIECE: VAULT TOP AT 15,200 LBS

CONCRETE: 5,000 PSI MIX
 REBAR: ASTM A615 GRADE 60
 AASHTO HS-20 RATED - ENGINEERING ON FILE

 Fairbanks Precast & Rebar	1122 Bradway Rd North Pole, AK 99705 PH: 907-488-9763 Fax: 907-488-8300	
	SCALE: NOT TO SCALE DATE: 11/9/18	DRAWN BY: TY JOHNSON REVISED:
FP&R STOCK ITEM CATALOGUE		
7138 VAULT TYPICAL STOCK LAYOUT	DRAWING NUMBER 1 OF 1	